

10-poliger Stecker

- 1 = MOSI
- 2 = 3,3...+5V
- 3 = nc
- 4 = Gnd
- 5 = Reset
- 6 = Gnd
- 7 = SCK
- 8 = Gnd
- 9 = MISO
- 10 = Gnd

Programmierstecker ISP

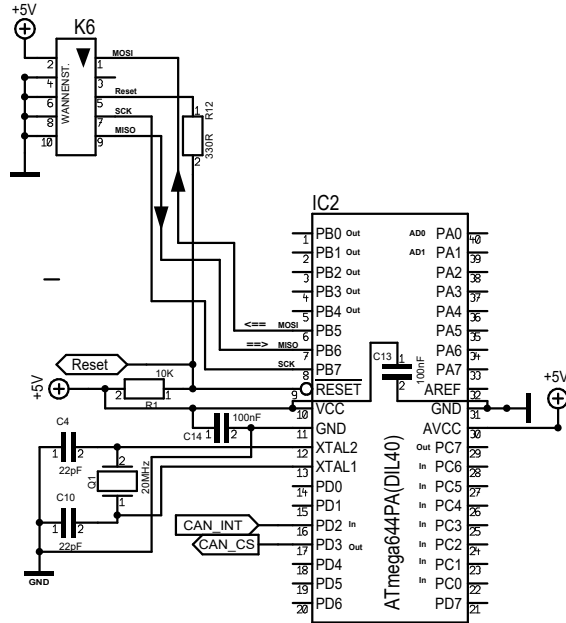

6-poliger Stecker

- 1 = MISO
- 2 = 3,3...+5V
- 3 = SCK
- 4 = MOSI
- 5 = Reset
- 6 = Gnd

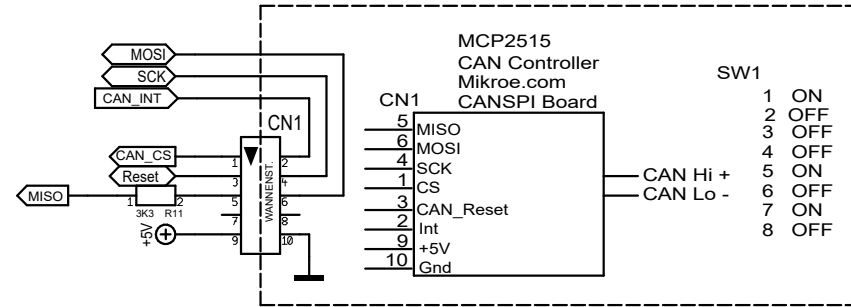

<http://www.mikroe.com/add-on-boards/communication/canspi/>

Maßstab	101,39%	Firma		Zeichner: Walter	Blatt
Änderung	31.12.15	13:32	<b>miControl CAN Interface</b>		
Ausgabe	31.12.15	13:44			
Datei	I2C_CAN.T3001	<b>Projekt:</b>			